

Reetech

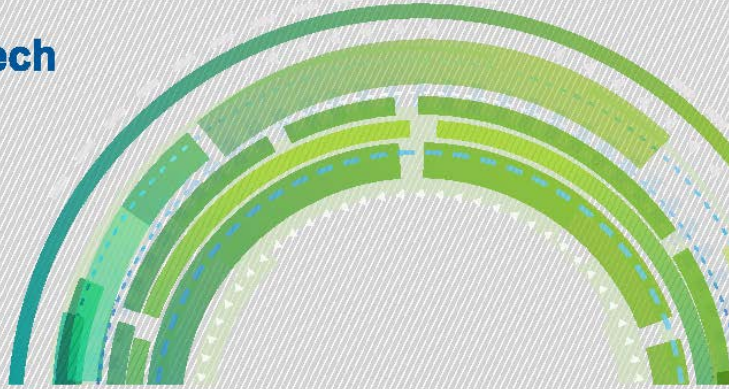

VAN GIÓ

QUI CÁCH SẢN PHẨM



DGD



OBD

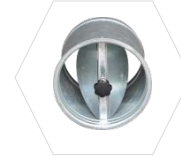

DGC



DGE

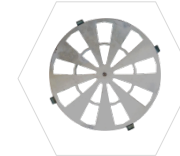

VCQ



MLD



CGA



CLA



CMC



CLB



CMC-F

MÃ SẢN PHẨM

STT	TÊN GỌI	MÃ ĐẶT HÀNG
1	VAN GIÓ CÁNH TÔN	DGE-WxH
2	VAN GIÓ CÁNH ĐÚC	MLD-WxH
3	VAN GIÓ TRÒN	DGD-D
4	VAN TRÒN CÁNH BƯỚM	DGC-D
5	VAN MIỆNG GIÓ	OBD-WxH
6	VAN MIỆNG GIÓ CÁNH QUẠT	VCQ-D
7	VAN CHẶN LỬA	CLA-WxH
8	VAN CHẶN LỬA TRÒN	CLB-D
9	VAN MỘT CHIỀU	CMC-WxH
10	VAN MỘT CHIỀU TRÒN	CMC-F-D
11	VAN CÂN BẰNG ÁP	CGA-WxHxL

01 VAN GIÓ CÁNH TÔN – DGE

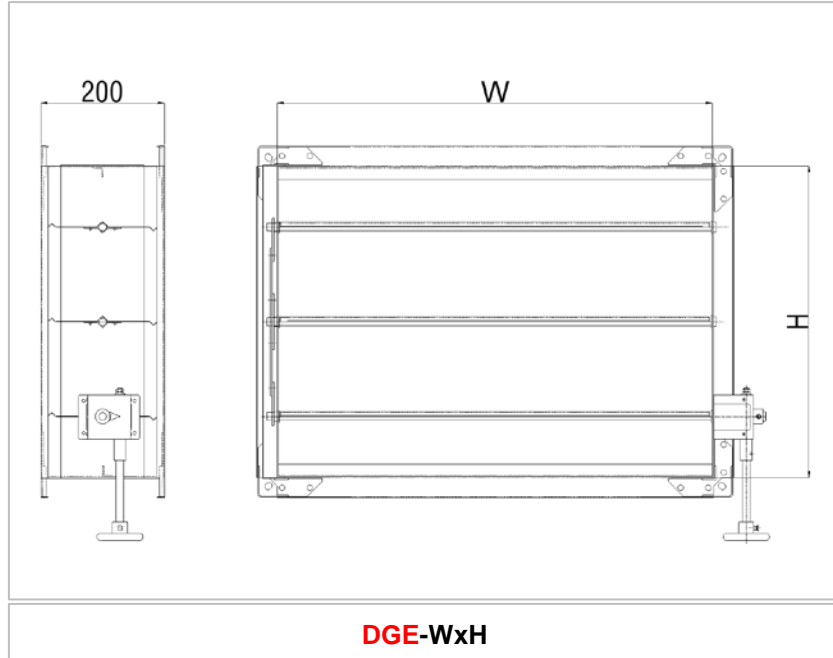

02 VAN GIÓ CÁNH ĐÚC – MLD

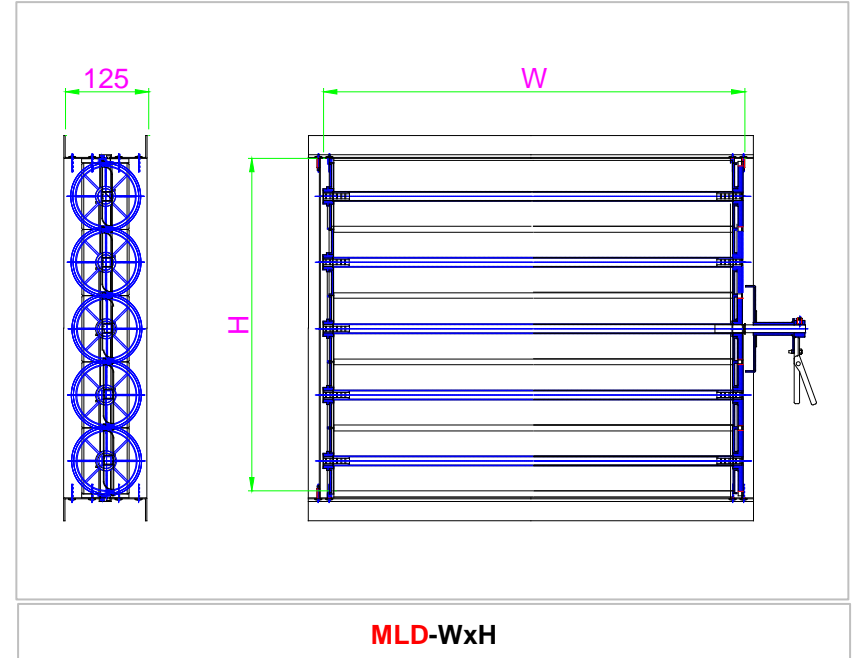

- Chiều cao $H = 100 [mm] \times \text{SỐ CÁNH}$

03 VAN GIÓ TRÒN – DGD

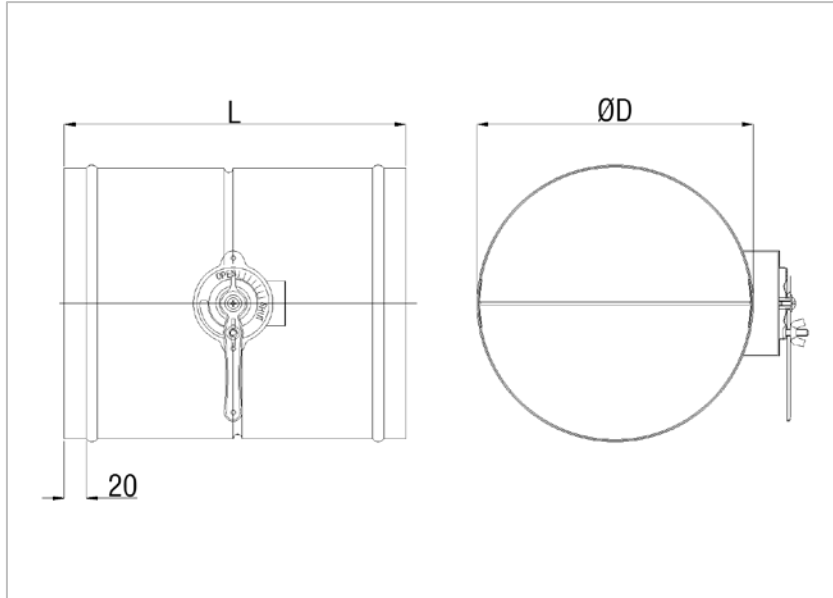

DGD-D

MODEL	DGD-100	DGD-150	DGD-200	DGD-250
ØD (mm)	95	145	195	245
L (mm)	150	190	240	290
Ø Ống gió	100	150	200	250

MODEL	DGD-300	DGD-350	DGD-400	DGD-450
ØD (mm)	295	345	395	445
L (mm)	340	390	440	490
Ø Ống gió	300	350	400	450

04 VAN GIÓ TRÒN CÁNH BƯỚM – DGC

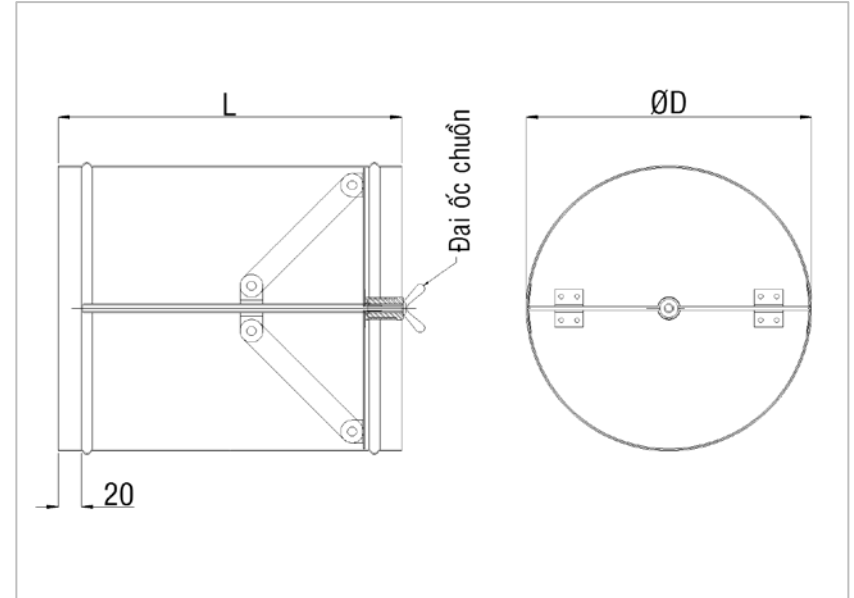

DGC-D

MODEL	DGC-100	DGC-150	DGC-200	DGC-250
ØD (mm)	95	145	195	245
L (mm)	150	190	240	290
Ø Ống gió	100	150	200	250

MODEL	DGC-300	DGC-350	DGC-400	DGC-450
ØD (mm)	295	345	395	445
L (mm)	340	390	440	490
Ø Ống gió	300	350	400	450

05 VAN MIỆNG GIÓ – OBD

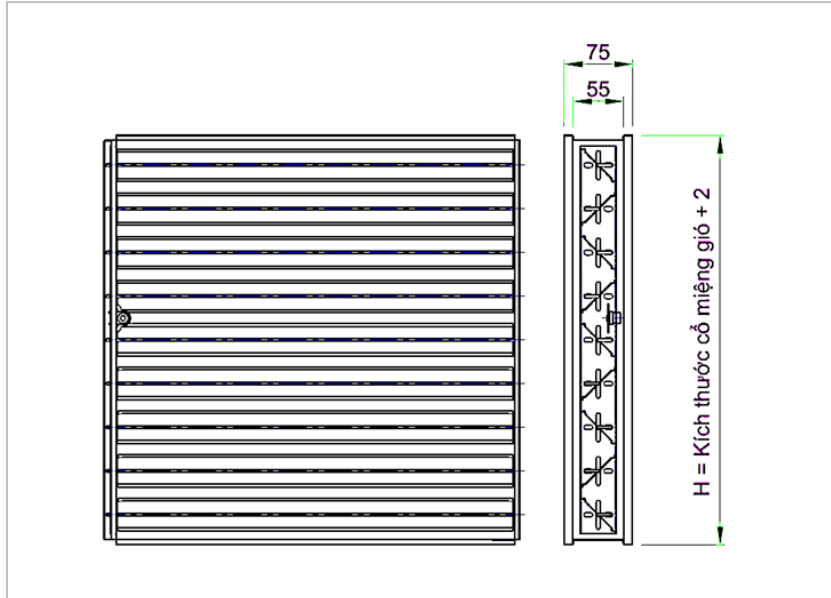

OBD-WxH

06 VAN MIỆNG GIÓ CÁNH QUẠT – VCQ

Loại VCQ có khóa chỉnh gió bên trong:

Loại VCQ có tay chỉnh gió bên ngoài:

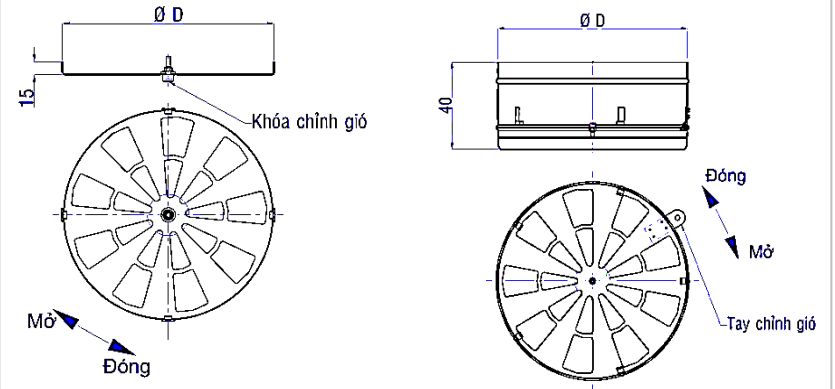

VCQ-D

MODEL	VCQ-185	VCQ-275	VCQ-300	VCQ-455	VCQ-545
Ø Cổ M/G	185	275	300	455	545
Ø D [mm]	183	273	298	453	543

07 VAN CHẶN LỬA – **CLA**

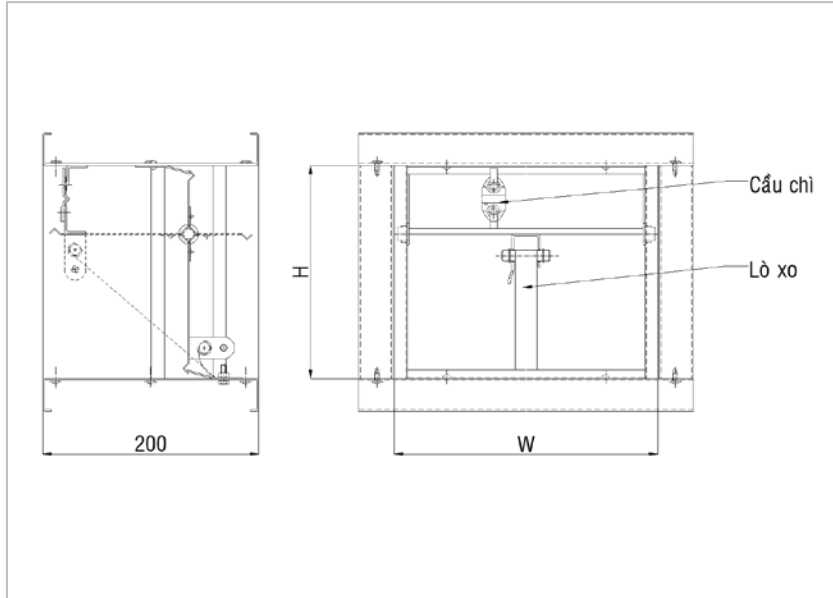

CLA-WxH

* Loại cầu chì nóng chảy ở 74°C

08 VAN CHẶN LỬA TRÒN – **CLB**

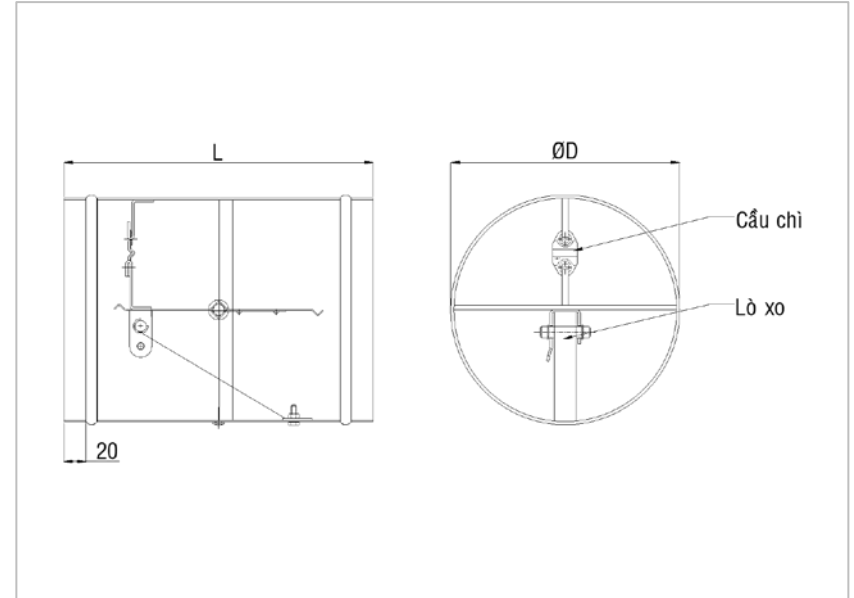

CLB-D

* Loại cầu chì nóng chảy ở 74°C

MODEL	CLB-100	CLB-150	CLB-200	CLB-250
ØD (mm)	95	145	195	245
L (mm)	150	190	240	290
Ø Ống gió	100	150	200	250

MODEL	CLB-300	CLB-350	CLB-400	CLB-450
ØD (mm)	295	345	395	445
L (mm)	340	390	440	490
Ø Ống gió	300	350	400	450

09 VAN MỘT CHIỀU – CMC

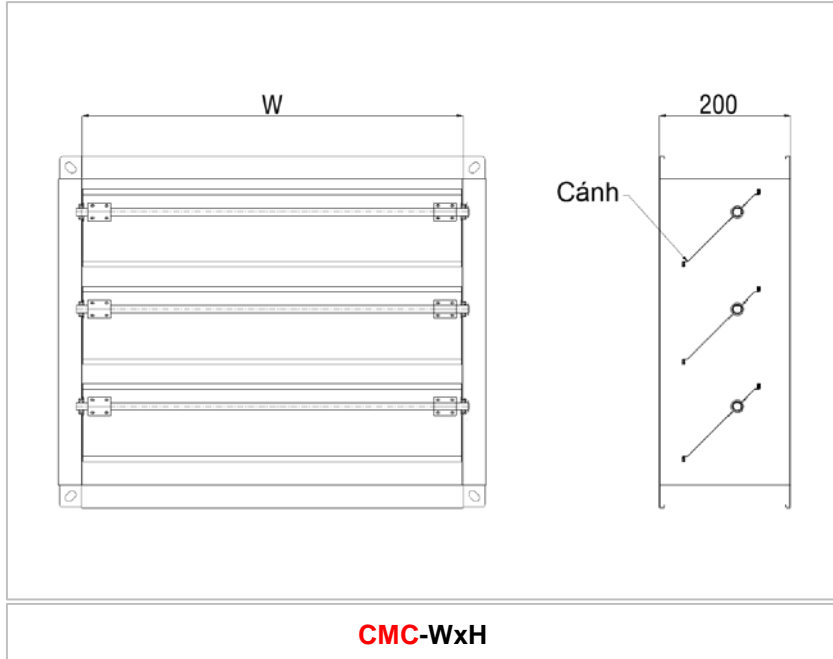

10 VAN MỘT CHIỀU TRÒN – CMC-F

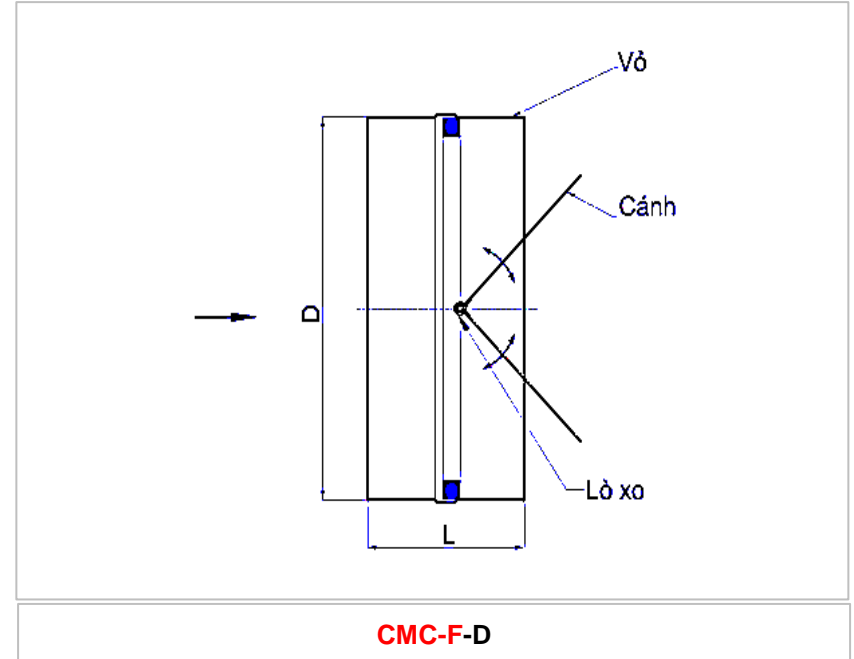

MODEL	CMC-F-100	CMC-F-150	CMC-F-200	CMC-F-250
ØD (mm)	95	145	195	245
L (mm)	150	190	240	290
Ø Ống gió	100	150	200	250

MODEL	CMC-F-300	CMC-F-350	CMC-F-400	CMC-F-450
ØD (mm)	295	345	395	445
L (mm)	340	390	440	490
Ø Ống gió	300	350	400	450

11 VAN CÂN BẰNG ÁP- CGA

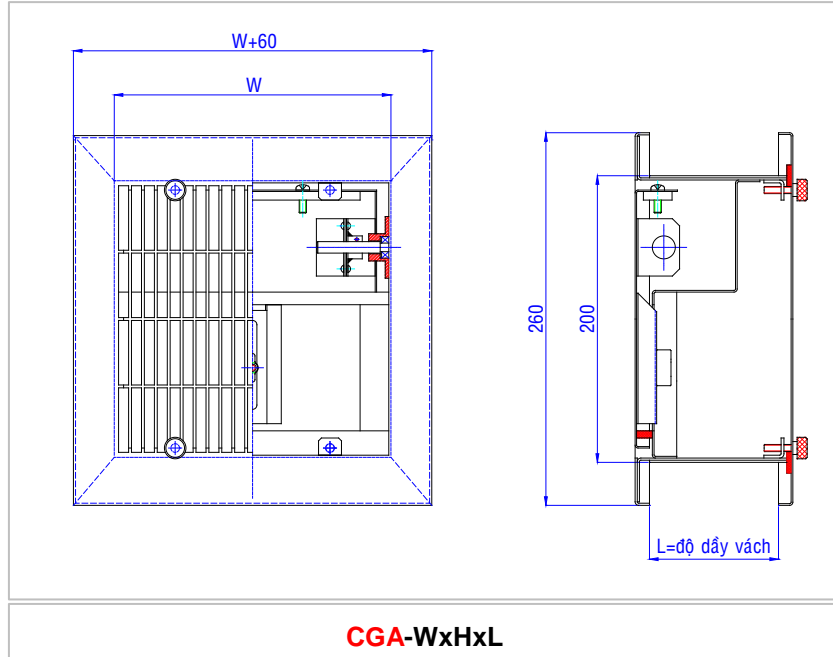

Model	CGA-200	CGA-400	CGA-600	CGA-800
W [mm]	200	400	600	800
H [mm]	200	200	200	200